

MEGALIFT *FSE*

Fast Silent Ergonomic



 **Megamat**

...we move for You

What can vitamin do for your com

Industrial IT
Industrial IT

World of Automation
World of Automation

Material Handl
Material Han

Warehouse
Warehouse

Quality Proc
Quality Pro

Production Eng
Production En

System Integration
System Integration

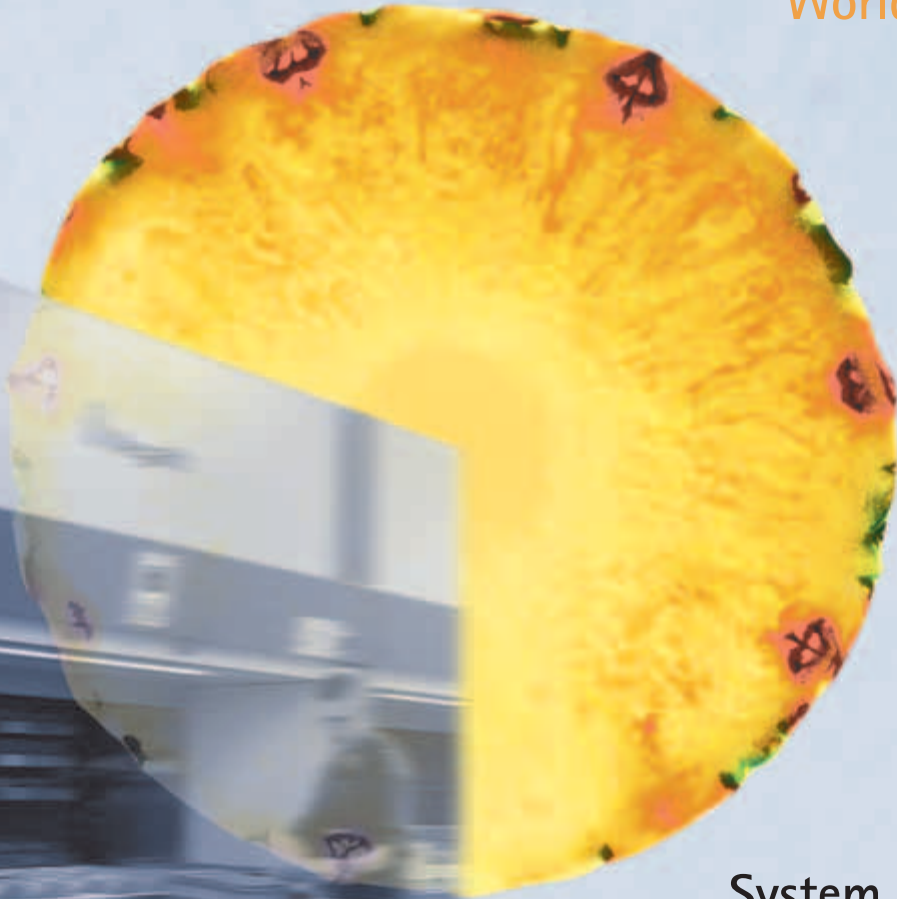

pany?

ing
ding

Management
Management

ess
cess

ineering
ineering

Efficient storage

FSE stands for fast, silent, ergonomic. Three features that ensure efficient storage. Faster through cycle times that are up to 25% shorter than our previous generation of lifts. Silent through the hoist cable technique. Ergonomic and technically perfected through attention to detail. Plus utmost safety through comprehensive protective devices and all this combined with high payload capacity.

Ergonomic working

The **MEGALIFT FSE** provides easy justification for decision makers: Its high speed ensures a high picking rate, thus boosting your company's productivity. Robustness and reliability are your guarantee of high operational safety and an exceptional service life. Megamat gives a 5-year warranty on the cable.*

Versatile use

Thanks to its silent operation and cleanliness, the **MEGALIFT FSE** is used in commissioning and distribution centres in the foodstuffs and pharmaceutical industries as well as many other types of industry. A fully automatic storage shelf system in your retail area as well as in Customer Service centres, the lift is ideally suited for many types of product and loads.

Easy operation

Several individually adjustable access heights plus ample headroom and foot clearance, put an end to strenuous back breaking work and there is no irritating noise. A sure way to raise employee motivation by creating a better working environment.

Quiet through cable hoist technology

Safe through comprehensive protective devices

Robust for high payloads

Fast through shorter cycle times

Technically perfected with many new options

Ergonomic through smart details

Full power everywhere



Application areas and implementation

Flexible and adaptable: Megalift solutions ensure top performance in many business activities.

The **MEGALIFT FSE** can be integrated into every logistics system. It acts as an extremely efficient warehouse, serves as a shipment buffer, or brings manufacturing processes to peak performance, and ... it only depends on your working procedures and tasks.

Megalift combination as a commissioning store with direct data link to order handling



Fixed attachment for retrieval with lift trucks



Strong and silent

Whether it's 1 kilogram or 1 ton, the Megalift will provide you with all the power your requirements need. The trays can accommodate containers, pallets, wiremesh boxes, and many other storage or stacking devices.

This enables you to store bulk goods, small parts, tools or entire assemblies safely and efficiently – always ready for fast retrieval.

Automated traversing process for production parts



Ergonomic deployment of parts



Easy handling of heavy tools



Solutions in constricted space



Different Megamat systems used in combination



Functional

Versatile

MEGALIFT FSE is a compact, fully automated high-bay storage system. Inside the unit, a computer controlled platform moves quickly and precisely. The platform collects the goods from the operating station, and transfers them to a suitable storage location – and retrieves them on demand. All of this happens “at the push of a button” via the ergonomically designed keyboard.

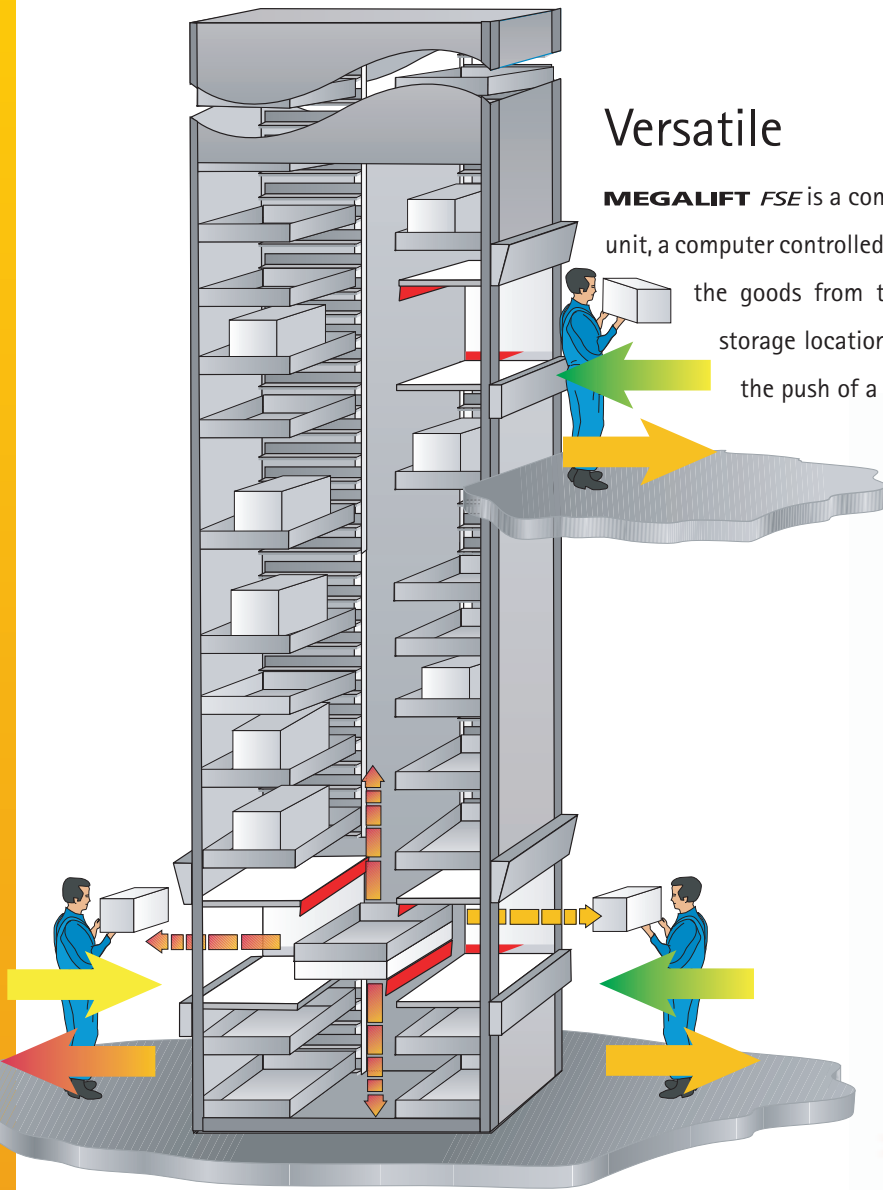

Combined lift and storage system: Storage and retrieval is possible at numerous levels

Excellent teamwork

The **MEGALIFT FSE** is capable of excellent teamwork: Several units can work together in combination. But that's not all: the system not only uses the available space right up to the ceiling but can also be fitted through ceilings and walls. So you can connect several storeys and rooms within a building, integrating up to five access openings – on both sides of the lift.

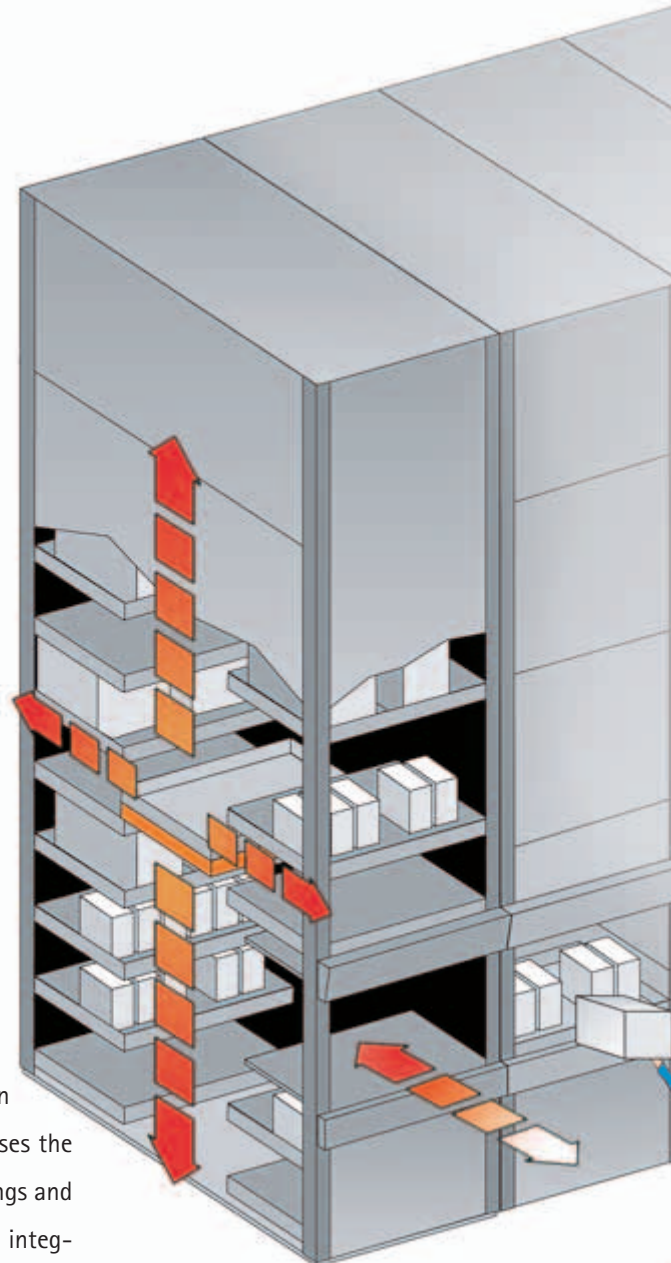



*Ideal for fast results:
Flexiloc system for
varying goods*

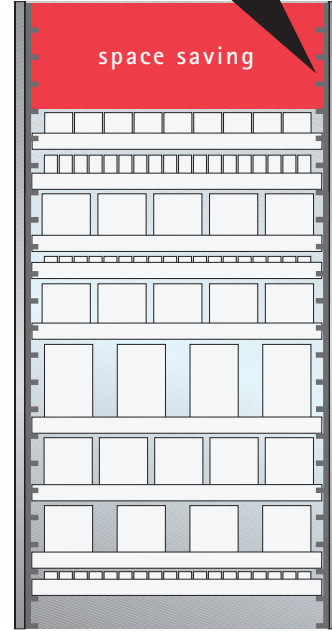
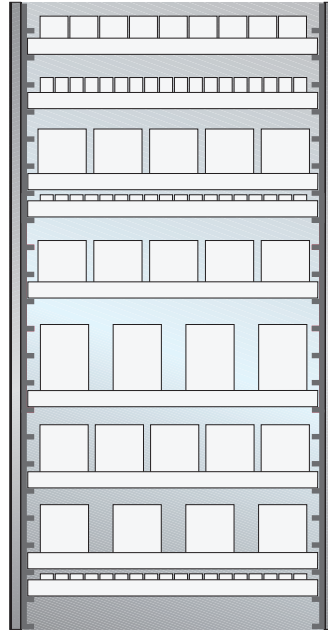

Fast and flexible!

Flexiloc system

Are you handling different goods with varying dimensions? If so, Flexiloc is the answer. The support brackets for the trays are equally spaced, i.e. the tray heights are adjustable in steps 25 mm. Thanks to the automatic height detection and an intelligent control system, the goods are always stored in the optimum location. This means maximum flexibility and the optimum utilization of available space.

Standard system

The ideal solution for all applications involving goods with uniform dimensions. During planning, you define the number and height of the storage bays. The tray support brackets are then mounted at the required spacing. However, by deciding for the Standard system you don't commit yourself. Conversion to a Flexiloc system is easily achievable.

*Combined solution for
efficient working*

A look at the technology

Drive system**

Optimised in all directions.

In the vertical dimension, a proven cable hoist system moves your goods quietly, quickly and reliably.

In the horizontal dimension, a crank drive accelerates the removal procedure. Steel cables have been used as reliable, heavy-load elements in machine engineering and materials handling systems for decades. They carry heavy loads, handle large quantities and have a long service life. State-of-the-art encoders bring the lift platform to exactly the right position every time.

*** The hoist system was developed in co-operation with the Institute for Materials Handling and Logistics at the University of Stuttgart.*



Foot clearance



Adjustable access height



Fast and quiet: hoist technology

Construction

Thanks to the mega-stable frame construction, 70 t can be loaded securely and safely with the **MEGALIFT FSE**. This structure allows for up to 5 access points at any required heights. Electronic safety devices guarantee fast, effective and safe picking. The 4-point suspension of the platform ensures the machine can cope with uneven loads.

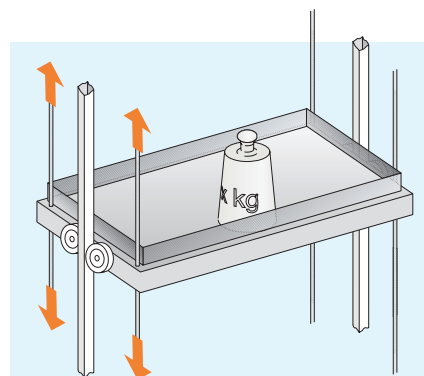

4-point-suspension



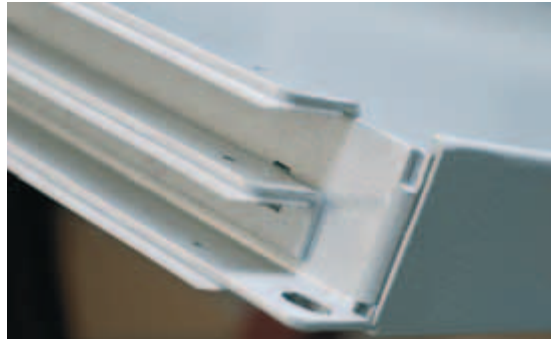

Variable trays for 25 mm Flexiloc

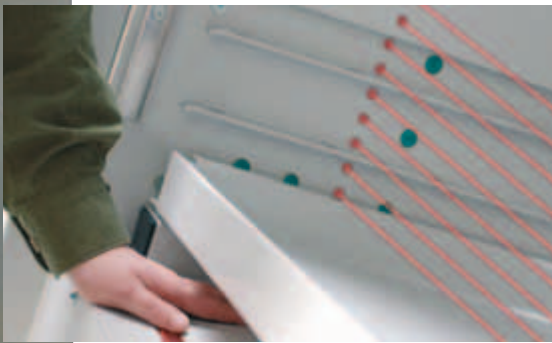

Light barrier set back, hand protection at the front



Easily accessible drawer for the control electronics

Drive

- Vertical: hoist technology for all weight classes
- Horizontal: crank drive
- 2 frequency converters
- Control with modern bus technology
- Quiet, clean, fast, wear-resistant
- Exact positioning
- Minimised switching times

Structure

- High load capacity
- Stable, robust, welded frame
- Modern attractive industrial design
- 4-point platform suspension
- Up to 5 access hatches on either side
- Headroom and foot clearance
- Individually adjustable access height
- Control keyboard at the top or on the side
- Electronic safety devices
- Vertical lifting door prevents chimney effects

Trays

- Mega-stable
- 25 mm Flexiloc spacing grid
- Chip coded for individual management
- Plain and roller bearings on the right and left
- Versatile separators and sub-divisions for trays

Separators and Features

Separators – variable and practical



... in different sizes,



... individually adjusted,



... and everything is safely stored.

Possible features

Barcode link, spot or laser pointer, additional safety devices, flat monitors: practically everything is possible with Megamat. Just ask your consultant!



Docking station for trolley. Complete trays can be transported in this way.



The position lightbar shows where to get a grip.



Barcode link: for safety, a clear overview and systematic working in your stores.

Colour variations



RAL 3003

5012

5019

6011

7012

7035

Available in 6 standard RAL colours, special colours on request.

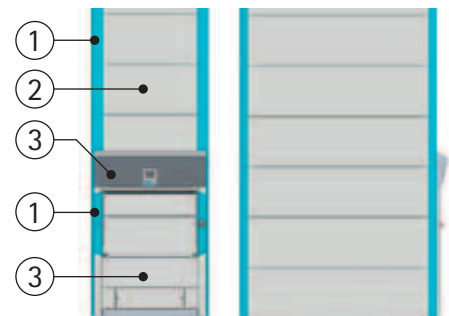

In 3 colours: chosen from the standard colours according to the customer specification.

- 1 Corner pieces, covers for the access hatch profile
- 2 Panelling plates
- 3 Access hatch with control box

Practical example: Argo Kraichtal project

Compact storage solves space problems:

As an international contact partner, ARGO-HYTOS offers system solutions for fluid technology from one single source. Argo was already suffering from a lack of space. A situation which was aggravated by further expansion. There was no possibility of extending the company premises either vertically or horizontally so ARGO decided to opt for qualitative area expansion. Within just 2 months, small parts storage in shelving systems covering an area of approx. 240 m² was transferred into six Megalifts with a height of 7 m. This saved approx. 190 m² of space. Megalogistik provided the corresponding inventory management.

Conclusion:

The current layout has integrated the whole Packaging area. Goods from the lift shelves are now picked according to the specific order and sent to the packaging department by the shortest route. "The quiet machines and modernisation of the workstations as a result of the project laid the foundations for manual workstations which are simply first-class in ergonomic terms", says Dr. Bernhard Steckel, Head of Logistics and Purchasing. The savings resulting from the conversion means that the investment costs will have been recouped by ARGO-HYTOS within 2.3 years.



Compact storage in lift shelves provides additionally required space.



Megalift combined with the Megalogistic inventory management software.

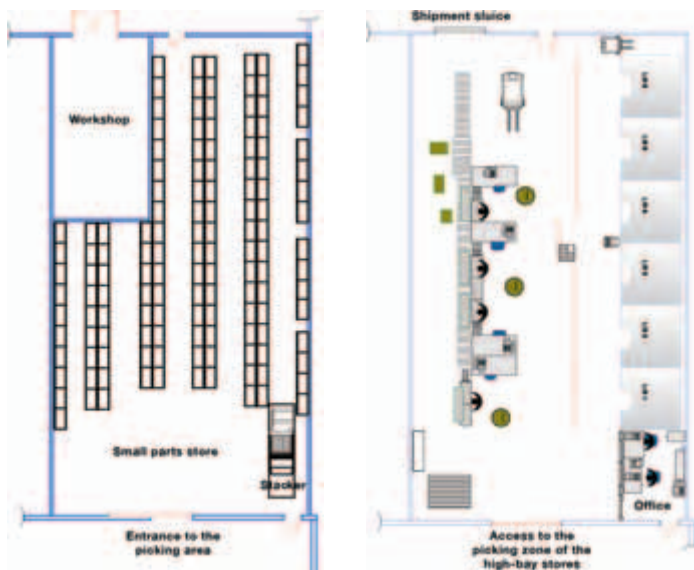

Layout of the small parts stores before and after conversion to the dynamic storage system.



MEGALIFT FSE: New top performance for your company

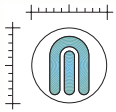

Brief details:

Lift height: approx. 2.5 m to 20 m

Overall dimensions: width from 1,412 mm to 4,064 mm, depth from 2,296 mm to 5,509 mm

Tray dimensions (internal): width from 1,020 mm to 3,672 mm, depth from 612 mm to 1,683 mm



Total stored weight per system: 70 t, up to 100 t on request

Load per tray:

Up to 337 kg, or 683 kg

depending on tray dimensions.



Max. height of stored goods up to 775 mm, taller goods on request

Flexiloc pitch: 25 mm for tray loads up to 683 kg

75 mm for tray loads from 683 kg

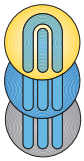

Customised adaptation of trays and their separators

Automated operation with MM240 controller, optionally with MM260

Stock management with M550 controller or Megalogistik software package

Automatic optimisation of storage space

Optimum storage locations for frequently accessed goods

Up to 5 access hatches

Displaced hatches possible

Systems available in numerous colour schemes

Outdoor installation on request

Special solutions and systems on request

We offer a 5-year warranty on the cables for single shift operation.

The standard scope of delivery does not include all the options and features described in the brochure.

Subject to technical changes without notice

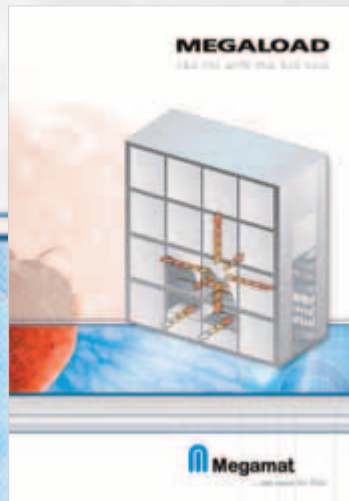

Megamat GmbH
Megamat-Platz 1
D-86476 Neuburg/Kammel

Phone: +49 (0) 82 83 / 999 - 0
Telefax: +49 (0) 82 83 / 999 - 144
Email: info@megamat.com
Web: www.megamat.com